

Activity—Digging for Fossils

Standard IV

Objective 1

Connections

Standard IV

Students will understand how fossils are formed, where they may be found in Utah, and how they can be used to make inferences.

Objective 1

Describe Utah fossils and explain how they were formed.

Intended Learning Outcomes

1. Use science process and thinking skills.
4. Communicate effectively using science language and reasoning.

Background Information

This activity is the result of a weeklong field experience with nine other teachers and the paleontologists from Brigham Young University working at the Dry Mesa, Colorado dinosaur quarry. While there, we had the opportunity to learn and use some basic skills in finding fossils. We learned about the care that must be taken in excavating and preserving the fossils that were found. We also learned that the exact location where each fossil that was found needed to be carefully entered on a map of the quarry. A grid system for establishing the location of fossils was set up with surveyed stakes and ropes. Before a prepared fossil could be moved from the site where it was found, it had to be entered on the map. Each of us had the opportunity to work side-by-side with professional paleontologists using the same tools and equipment to remove fossil specimens from sandstone. Each of the teachers made fossil discoveries of their own, from an allosaurus tooth to a brachiosaurus femur.

The challenge was to make this experience into a hands-on unit that could be shared with students in the classroom. Because the activity is based on digging for “fossils,” it was necessary to develop a dinosaur dig that could be done in the classroom. The search for a box to house the “digs” turned up in the school lunch program a box used to ship frozen corn dogs. The box has a lid than can be folded back to allow students to work inside. (See the attached drawing.) These boxes filled with coarse sand to a depth of about eight centimeters provide an excellent place to dig for “fossil” bones. The bones used in the box are specially prepared turkey bones and rodent bones. (See the instructions for preparing fossil dig boxes.)

A grid is set up in the dig for mapping purposes by stretching string between brass fasteners at the front and the back of the box, and from end to end of the box. Students receive an 8 1/2x11 inch piece of paper with a grid drawn on it which they label and use to “map the dig.” No bone may be taken from the dig until its position has been plotted and drawn on the map.

Invitation to Learn

What is it like to work in a fossil dig? What do paleontologists do to help them see the relationships between the fossils they are digging?

Instructional Procedures

1. Organize participants into cooperative teams of four.
2. Teams will prepare to map their “fossil dig” by labeling their 2" x 2" grid paper to match the grid on the dig box (journaling).
3. Once the “map” is ready, each team will open their dig box – remove the paper plate, spoon, fork, and brush and set them beside the box.
4. Set up a grid across the top of the dig box by stretching the string between the brass fasteners.
5. Students will take turns digging for bones, charting on the map where each bone is found, labeling each bone, and placing the labeled bones on the paper plate.
6. The spoon, fork, and brush may be used as tools for digging up bones. Be sure that the students are aware that there are large bones and small bones in the box, and that they need to dig carefully to find the ones.
7. No bone may be removed from the “dig” until its position has been plotted and drawn on the map and given an identification number.
8. Digging will continue until each participant has found at least two bones. (The bones from the dig will be saved on the plate along with the map to be used in the next activity.)

Materials

- Previously prepared “dinosaur dig” boxes
- Heavy paper plates
- Plastic spoons and forks
- 1 inch wide paint brushes
- 8 1/2 x 11 inch paper with a 2" x 2" grid
- Pencils
- 1" x 1" sticky notes

Curriculum Integration

Math/Science—Using coordinates to plot positions on a map.

Additional Resources

See the attached Additional Resources list.

Family Connections

Share a variety of options for teachers to explore and use.

Preparing Fossil Dig Boxes

1. Obtain boxes. Ideal boxes for fossil digs are the boxes frozen corn dogs are shipped in. You may obtain some from the lunch program at your school. These boxes are 42 cm long, 28 cm wide, and 13 cm deep. They have an attached lid that can be folded back to allow students to work inside (see drawing).
2. Fill 8 cm of each box with coarse cement sand. This provides an excellent place to dig for "fossil" bones.
3. Find something to use for "fossil" bones. Leftover turkey bones from thanksgiving dinner work exceptionally well as larger fossils. Boil the bones until all traces of fat and tissue are removed. With the connective tissue gone, the bones separate nicely to provide many individual bones with which to work.
4. Place the bones on a cookie sheet and bake them for two hours in the oven at 110 C. until they are completely dry and germ-free.
5. Divide the bones between ten sand boxes.
6. For smaller "fossils," disassemble barn owl pellets, which can be obtained from a commercial science supply house. Each pellet should provide enough small rodent bones for one of the dig boxes, including one or more rodent skulls. The small bones force the students to search slowly and carefully through the sand so that none are missed.
7. Bury the bones in the sand and prepare to watch your students get excited about digging for "fossils."
8. Name each of the boxes after a Fossil Dig Site in Utah.
9. Use brass fasteners and heavy string to form an 8x8-cm grid across the top of the box. As students locate a bone, they can use the grid to locate the map coordinates to show where each bone is found.
10. Across the front of the box, label the spaces 1 – 6. Across the side of the box, label the spaces A – D. (Once again see the attached drawing of the box.)
11. You now have created fossil dig sites you can use with students to help them understand how paleontologists work. Talk to the students about how the relationships of bones to each other in the dig may give them clues to make inferences about the interrelationships of the animals.
12. Place a heavy-duty paper plate in each box with a plastic spoon, plastic fork, and an inch-wide paintbrush. These are the digging tools students will use to extract bones from the boxes. When the bones have been assigned a number and mapped on the grid sheet, use a 1" x 1" sticky note to label and number each bone.

Fossil Dig Boxes

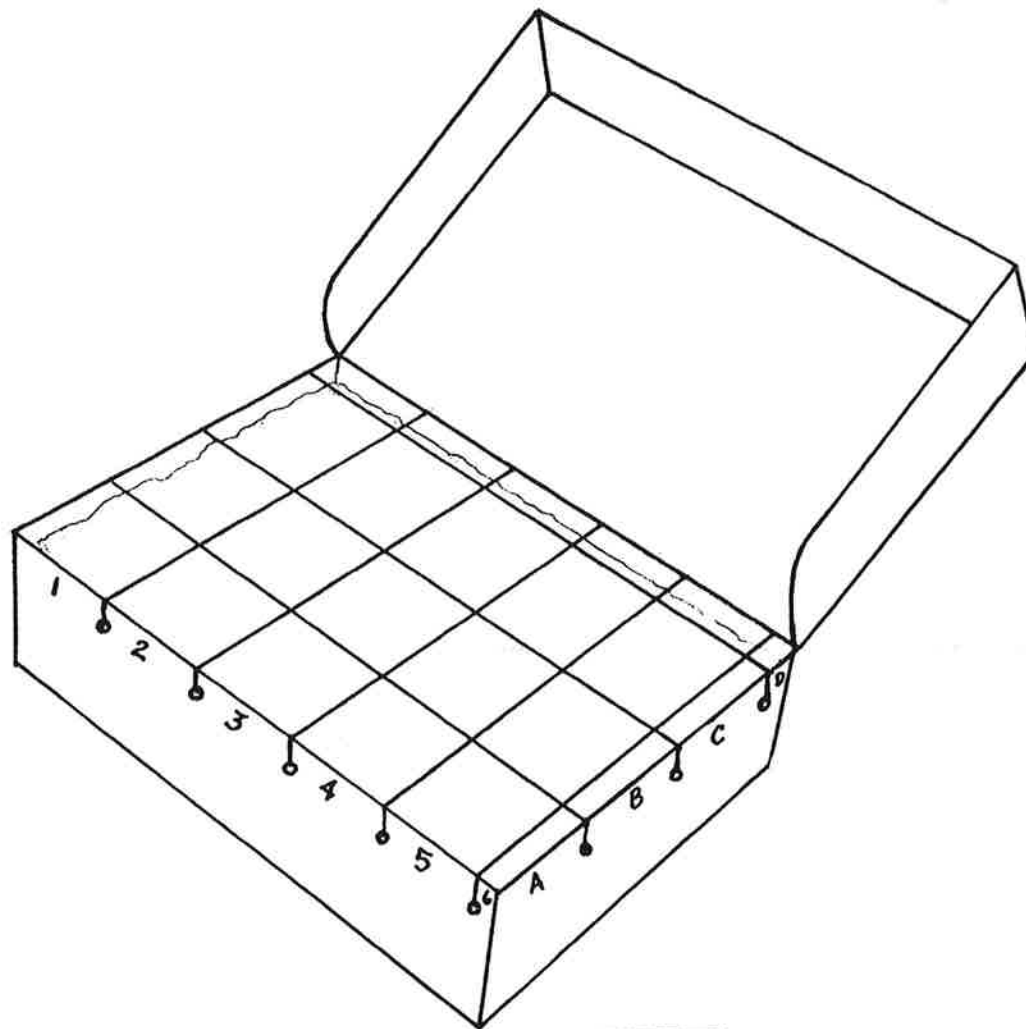

1	2	3	4	5	6
					D
					C
					B
					A